

# Dispermill X-Proof HX400

 Pilot Dissolver

The Dispermill X-Proof HX400 is designed for the bigger laboratory research and development projects and pilot plants. The H-shaped floor stand ensures stability on the dissolver and the counterweight provides a balance that eases to move the machine up and down with the ergonomic lever. The powerful motor maintains its selected speed, independent of changes in viscosity. This guarantees optimum performance for your dissolving process. Besides, the stainless steel design is easy to maintain.

## SAFETY FIRST

Your safety is very important to us. Safety interlocks for vessel detection and operation height are developed to ensure that no hazardous situations occur. This means that you can focus on your activities without being worried. The X-Proof HX400 is designed to operate in potentially explosive atmospheres.

## APPLICATION

The Dispermill X-Proof HX-400 fills the gap between the laboratory and the production dissolvers. Do you need a bigger testing sample or a smaller production batch and a machine that operates in potentially explosive atmospheres? That's where the Dispermill X-Proof HX400 comes in.

## FEATURES

- ✓ Speed control by frequency inverter
- ✓ Digital speed readout
- ✓ Separate electronic cabinet
- ✓ Vessel clamping system
- ✓ 5 m cable between dissolver and electric cabinet included (other length on request)
- ✓ 150 mm dispersing disc included

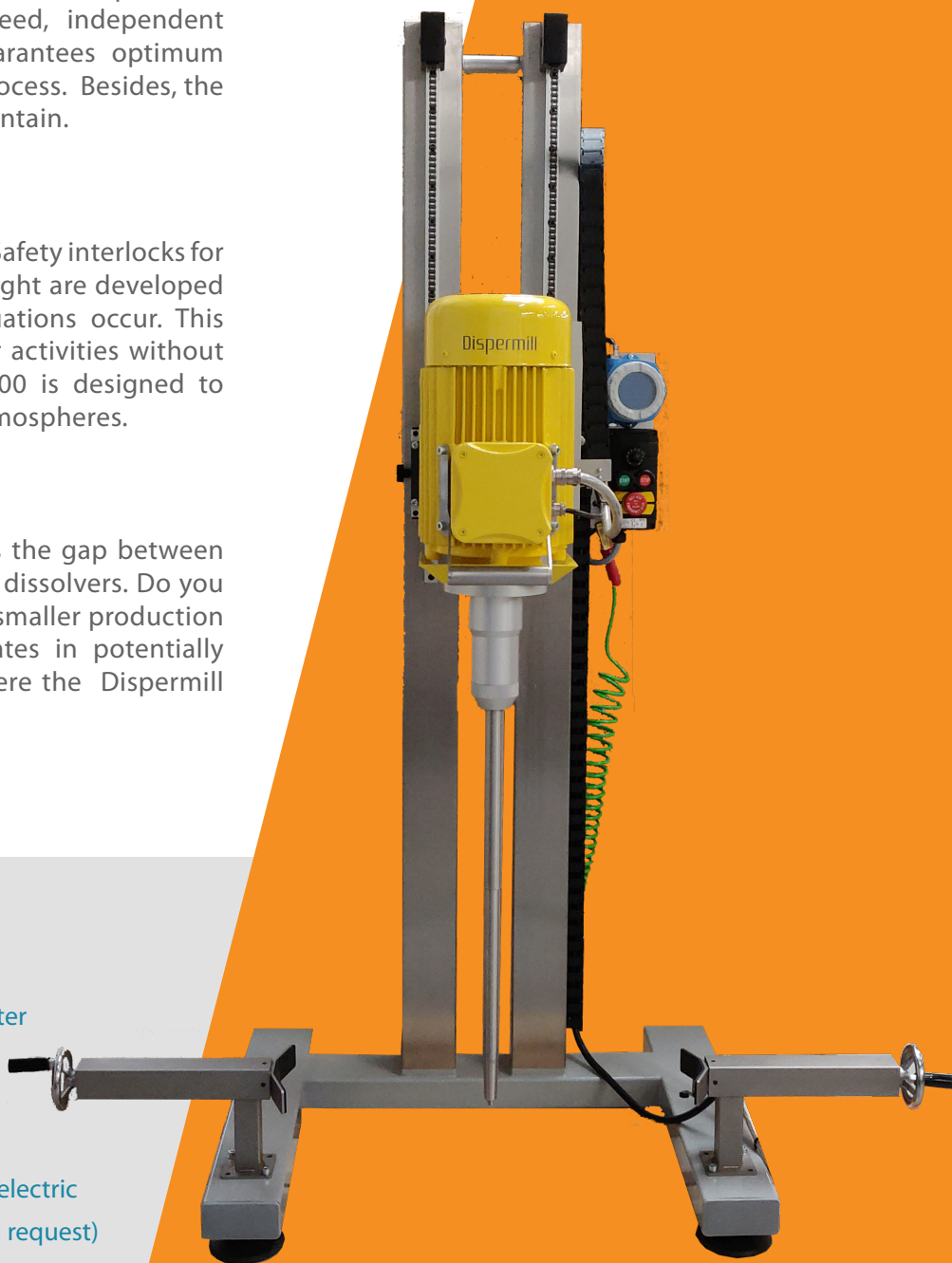

**Dispermill X-Proof HX400**

4.0 kW, 0 - 4.000 RPM, 15 L - 150 L

**Order code**

10-1102

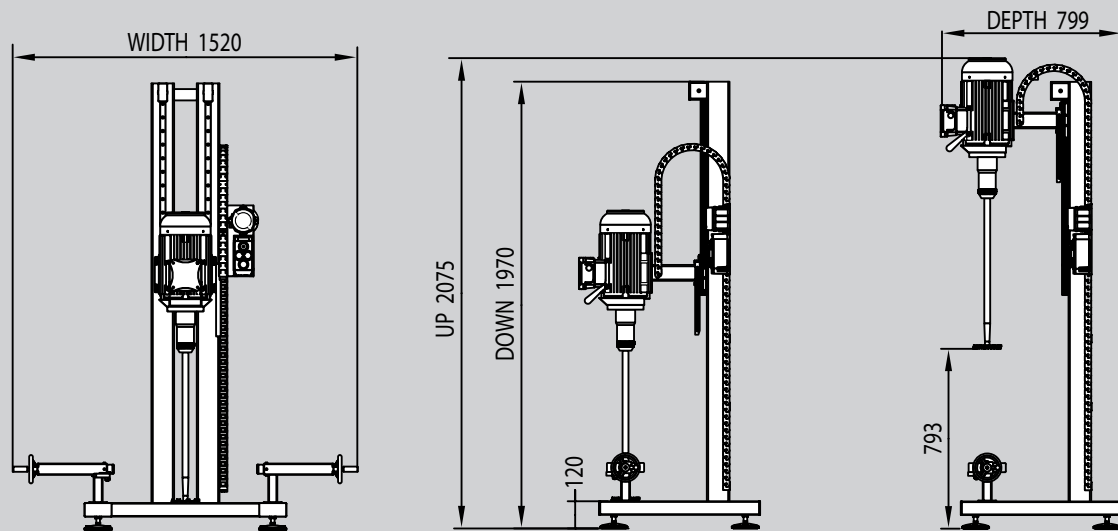

## TECHNICAL SPECIFICATIONS

<b>Power</b>	4,0kW / 5 HP
<b>Supply</b>	400 V +/- 10% 50/60 Hz, 16 Ampere
<b>Protection class</b>	 II 2G IIB T3
<b>Speed</b>	0 till 4.000 RPM
<b>Thermal protection</b>	PTC Temperature sensors
<b>Volume range vessel</b>	15 - 150 L
<b>Diameter vessel</b>	150 - 630 mm (min. - max.) <sup>1</sup>
<b>Height vessel</b>	300 - 780 mm (min. - max.)
<b>Dispersing disc</b>	150 mm (interchangeable)
<b>Dimensions (in mm)</b>	799 x 1520 x 1970/2075 (D x W x H)
<b>Weight</b>	+/- 170 KG
<b>Readout</b>	True shaft speed on clear blue display
<b>Safety CE</b>	Conformity Directive 2006/42/EC
<b>Electrical cabinet</b>	Dimensions: 500 x 400 x 210 mm. Requires placement outside of ATEX zone.

<sup>1</sup> in combination with default clamping system

## OPTIONS



Dual spindle clamping  
(default)

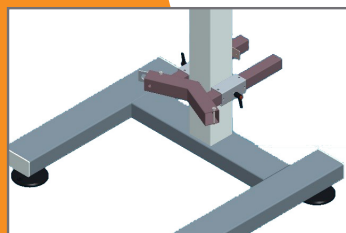

Belt clamping system  
+033

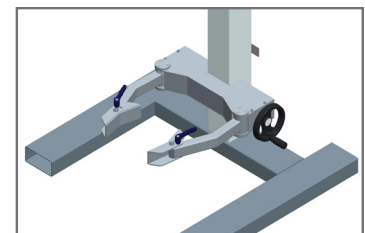

Central clamping system  
+032

- +015 Power readout in kW
- +011 Mechanical timer with automatic stop 120 min
- +050 Vessel cover systems (on request)